



88116506

**PHYSICS
STANDARD LEVEL
PAPER 3**

Thursday 10 November 2011 (morning)

1 hour

Candidate session number

0	0								
---	---	--	--	--	--	--	--	--	--

Examination code

8	8	1	1	-	6	5	0	6
---	---	---	---	---	---	---	---	---

INSTRUCTIONS TO CANDIDATES

- Write your session number in the boxes above.
- Do not open this examination paper until instructed to do so.
- Answer all of the questions from two of the Options.
- Write your answers in the boxes provided.



0136

Option A — Sight and wave phenomena

A1. This question is about photopic vision and scotopic vision.

(a) State the difference between photopic vision and scotopic vision.

[1]

.....
.....
.....

(b) At dusk, the petals of a red flower appear to be much duller than the surrounding leaves.

Outline, in terms of the functions of the rod and the cone cells in the retina, the reasons for this observation.

[3]

.....
.....
.....
.....
.....
.....
.....



A2. This question is about standing waves in an organ pipe.

(a) The diagram shows an organ pipe that is open at both ends.

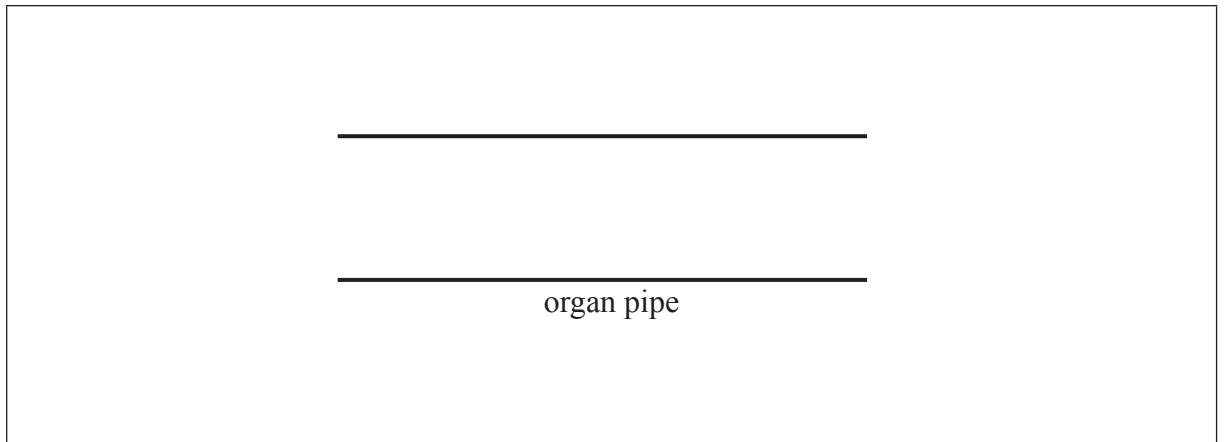

The pipe is emitting its lowest frequency note.

On the diagram above,

- (i) sketch a representation of the standing wave set up in the pipe. [1]
 - (ii) label with the letter P, the point **or** points within the pipe where the air pressure is a maximum. [1]
 - (iii) label with the letter A, the displacement antinodes. [1]
- (b) The length of the pipe in (a) is 1.5 m. An organ pipe that is closed at one end has the same lowest frequency note as the pipe in (a).

Show that the length of this pipe is 0.75 m. [2]

.....

.....

.....

.....



A3. This question is about diffraction and polarization.

(a) Light from a monochromatic point source S_1 is incident on a narrow, rectangular slit.



After passing through the slit the light is incident on a screen. The distance between the slit and screen is very large compared with the width of the slit.

(i) On the axes below, sketch the variation with angle of diffraction θ of the relative intensity I of the light diffracted at the slit. [2]

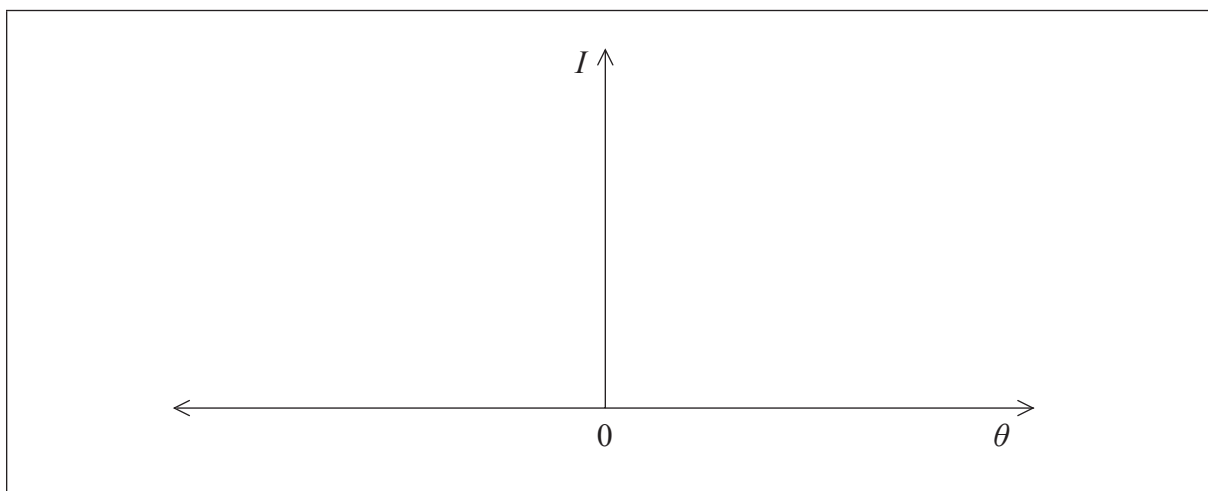

(This question continues on the following page)



(Question A3 continued)

- (ii) The wavelength of the light is 480 nm. The slit width is 0.1 mm and its distance from the screen is 1.2 m. Determine the width of the central diffraction maximum observed on the screen. [3]

.....

.....

.....

.....

.....

.....

.....

- (b) Judy looks at two point sources identical to the source S_1 in (a). The distance between the sources is 8.0 mm and Judy's eye is at a distance d from the sources.

Estimate the value of d for which the images of the two sources formed on the retina of Judy's eye are just resolved. [3]

.....

.....

.....

.....

.....

.....

.....

(This question continues on the following page)



(Question A3 continued)

- (c) The light from a point source is unpolarized. The light can be polarized by passing it through a polarizer.

Explain, with reference to the electric (field) vector of unpolarized light and polarized light, the term polarizer.

[3]

.....

.....

.....

.....

.....

.....

.....



Option B — Quantum physics and nuclear physics

B1. This question is about the photoelectric effect.

- (a) The diagram shows the set up of an experiment designed to verify the Einstein model of the photoelectric effect.

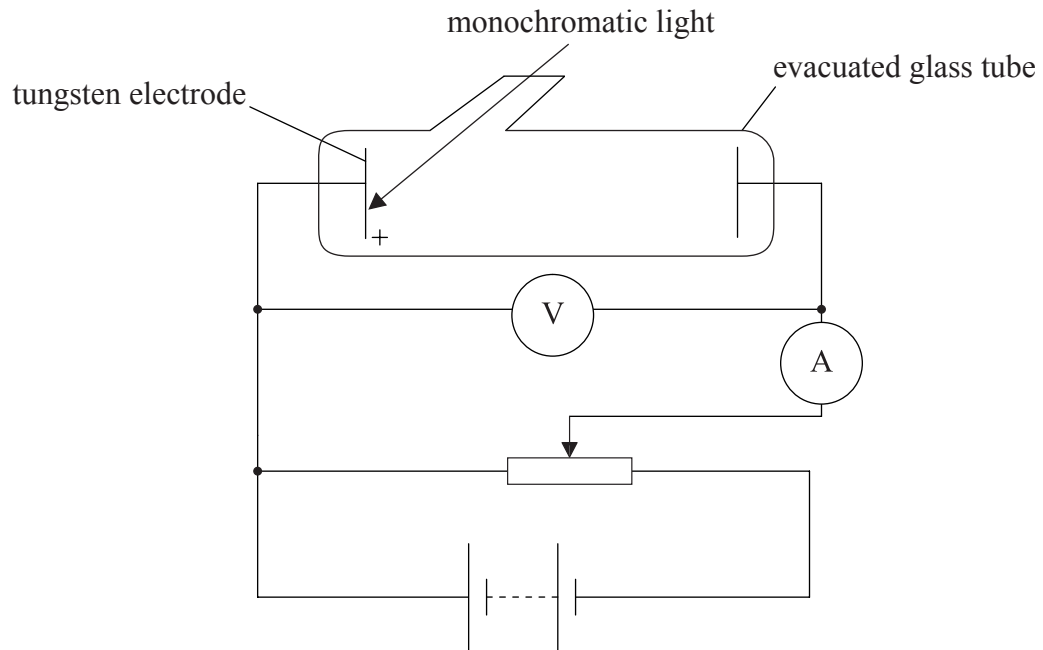

The tungsten electrode is positive.

Explain how the maximum kinetic energy of electrons ejected from the positive electrode is determined. [3]

.....

.....

.....

.....

.....

.....

.....

(This question continues on the following page)



(Question B1 continued)

(b) Light of frequency f is shone onto the tungsten electrode in (a). The potential V_s for which the photoelectric current is zero is recorded for different values of f .

(i) Using the axes below, sketch a graph of how you might expect V_s to vary with f . [2]

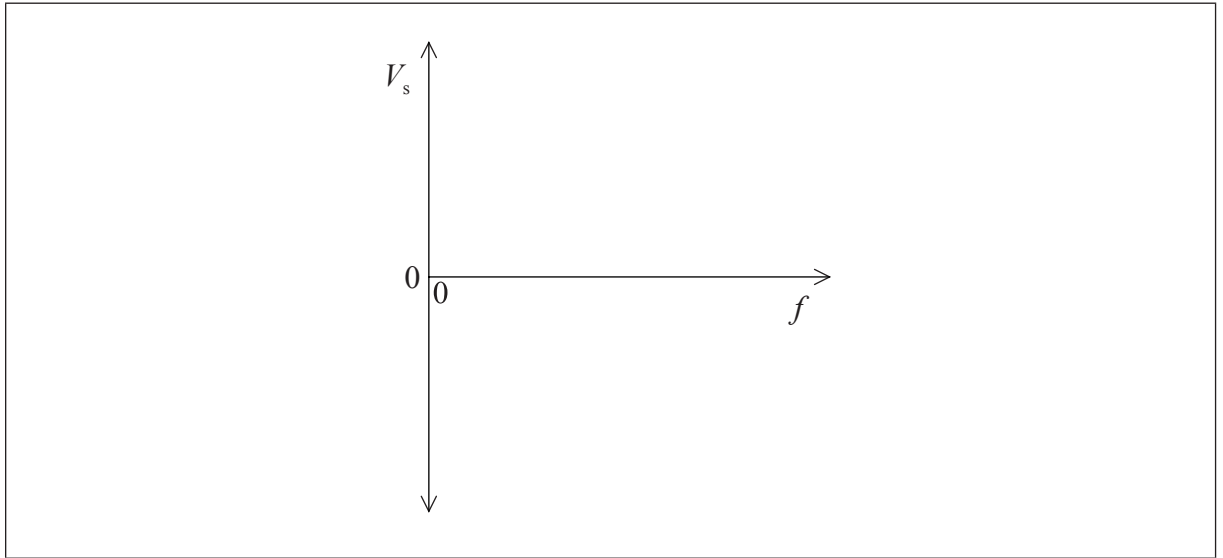

(ii) State the Einstein photoelectric equation in a form that relates V_s and f . Define, other than the electron charge, any other symbols that you might use. [3]

.....
.....
.....
.....
.....
.....
.....

(This question continues on the following page)



(Question B1 continued)

- (iii) Outline how a graph of V_s against f can be used to find the Planck constant and work function of tungsten. [2]

Planck constant:

.....

.....

Work function:

.....

.....

- (c) The work function of tungsten is 4.5 eV. Show that the de Broglie wavelength of an electron that has this energy is about 0.6 nm. [3]

.....

.....

.....

.....

.....

.....

.....



B2. This question is about alpha particles.

(a) Alpha particle scattering experiments suggest that the diameter of the nucleus of a gold atom is about 3×10^{-14} m.

(i) Show that the energy of the alpha particles that lead to this estimate of the nuclear diameter is about 8 MeV. (Proton number of gold = 79) [3]

.....

.....

.....

.....

.....

.....

.....

(ii) A source of alpha particles used in scattering experiments is the decay of an isotope of thorium. State how such decays provide evidence for the existence of nuclear energy levels. [1]

.....

.....

(b) The thorium isotope in (a)(ii) has a half-life of several thousand years. Outline how the half-life is measured. [3]

.....

.....

.....

.....

.....

.....

.....

Option C — Digital technology

C1. This question is about CDs.

- (a) Outline, with reference to its structure, how the interference of light is used to recover information stored on a CD. [3]

.....

.....

.....

.....

.....

.....

.....

.....

- (b) The wavelength of light used to read data from a particular CD is 780 nm. Estimate the depths of the pits on the CD surface. [2]

.....

.....

.....

.....



C2. This question is about charge-coupled devices (CCDs).

(a) Define the term *magnification* as related to a CCD.

[1]

.....

.....

(b) Discuss the effects of magnification and resolution on the quality of the image retrieved from a CCD.

[4]

Magnification:

.....

.....

.....

.....

.....

Resolution:

.....

.....

.....

.....

.....



C3. This question is about operational amplifiers.

(a) The circuit diagram shows an operational amplifier connected as an inverting amplifier.

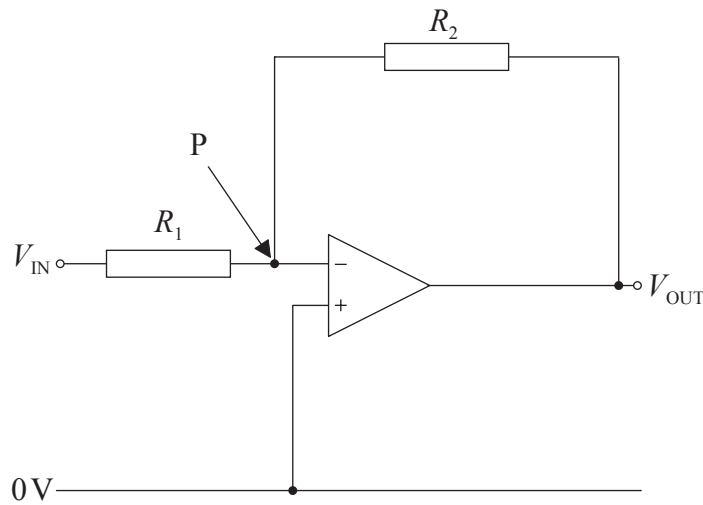

(i) Explain, with reference to the properties of an operational amplifier, why point P is effectively at zero potential. [4]

.....

.....

.....

.....

.....

.....

.....

.....

.....

.....

(ii) Derive an expression for the gain G of the amplifier. [2]

.....

.....

.....

.....

(This question continues on the following page)



(Question C3 continued)

(b) In the circuit below, an operational amplifier is used as a comparator.

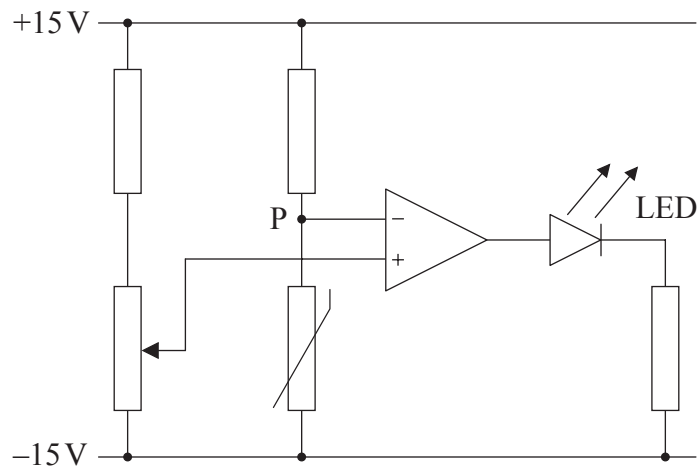

The amplifier operates from a $\pm 15\text{V}$ supply. If the thermistor reaches a certain temperature then, to act as a warning, the light-emitting diode (LED) switches on.

Describe, with reference to the potential at point P, the operation of the circuit.

[4]

.....

.....

.....

.....

.....

.....

.....

.....

.....



Option D — Relativity and particle physics

D1. This question is about special relativity, simultaneity and length contraction.

(a) One of the two postulates of special relativity may be stated as:

“The laws of physics are the same for all observers in inertial reference frames.”

State

(i) what is meant by an inertial frame of reference. [1]

.....

.....

(ii) the other postulate of special relativity. [1]

.....

.....

(This question continues on the following page)



(Question D1 continued)

- (b) In a thought experiment to illustrate the concept of simultaneity, Vladimir is standing on the ground close to a straight, level railway track. Natasha is in a railway carriage that is travelling along the railway track with constant speed v in the direction shown.

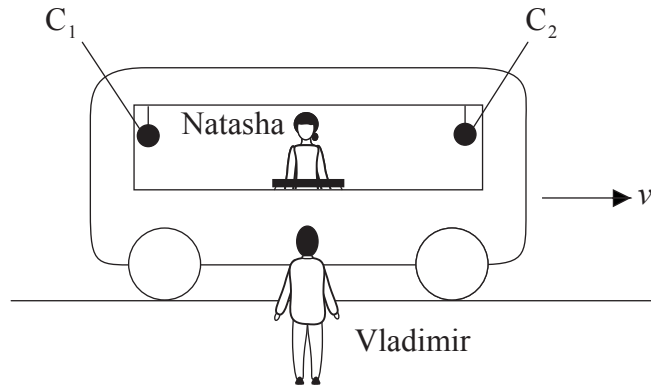

Natasha is sitting on a chair that is equidistant from each end of the carriage. At either end of the carriage are two clocks C_1 and C_2 . Next to Natasha is a switch that, when operated, sends a signal to each clock. The clocks register the time of arrival of the signals. At the instant that Natasha and Vladimir are opposite each other, Natasha operates the switch. According to Natasha, C_1 and C_2 register the same time of arrival of each signal.

Explain, according to Vladimir, whether or not C_1 and C_2 register the same time of arrival for each signal.

[4]

.....

.....

.....

.....

.....

.....

.....

.....

.....

.....

(This question continues on the following page)



(Question D1 continued)

(c) The speed v of the carriage is $0.70c$. Vladimir measures the length of the table at which Natasha is sitting to be 1.0 m .

(i) Calculate the length of the table as measured by Natasha. [3]

.....

.....

.....

.....

.....

(ii) Explain which observer measures the proper length of the table. [1]

.....

.....

.....



D2. This question is about electrons and the weak interaction.

(a) State

(i) what is meant by an elementary particle.

[1]

.....
.....

(ii) to which class of elementary particles the electron belongs.

[1]

.....

(b) An electron in an excited state of the hydrogen atom has an energy of 1.5 eV.

Show that the maximum time that the electron can spend in this state is 2.2×10^{-16} s.

[2]

.....
.....
.....
.....

(This question continues on the following page)



(Question D2 continued)

(c) An electron is one of the particles produced in the decay of a free neutron into a proton. An exchange particle is also involved in the decay.

(i) State the name of the exchange particle. [1]

.....

(ii) The weak interaction has a range of the order of 10^{-18} m. Determine, in GeV c^{-2} , the order of magnitude of the mass of the exchange particle. [3]

.....
.....
.....
.....
.....

(iii) It is suggested that the exchange particle in the weak interaction arises from the decay of one type of quark into another. With reference to the quark structure of nucleons, state the reason for this suggestion. [2]

.....
.....
.....
.....



Option E — Astrophysics

E1. This question is about stellar distances and stellar properties.

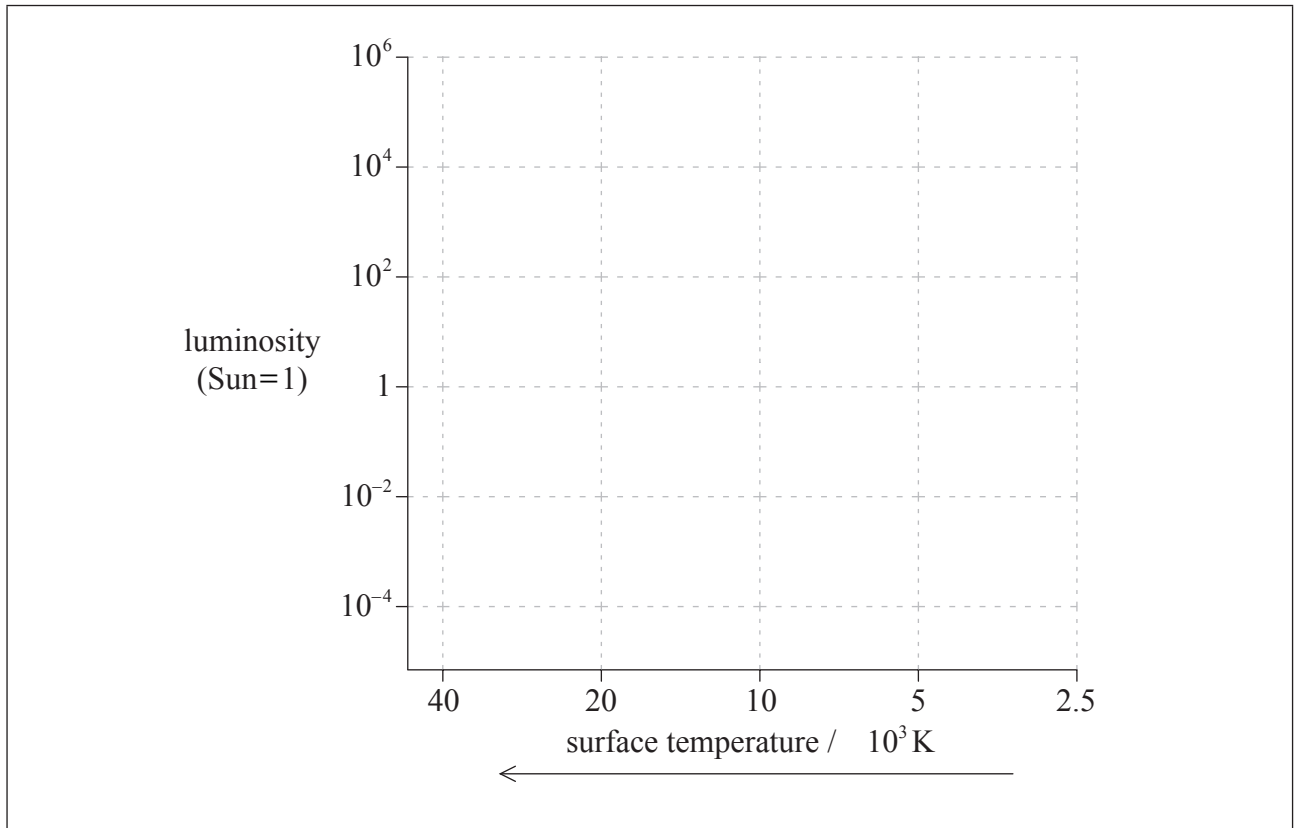

- (a) On the grid of the Hertzsprung–Russell (HR) diagram shown, draw a line to represent the approximate position of the main sequence. [2]

- (b) Barnard’s star is a main sequence star that is 1.8 pc from Earth.
 - (i) Define the *parsec*. [1]

.....

.....

(This question continues on the following page)



(Question E1 continued)

- (ii) Calculate the parallax angle of Barnard's star as measured from Earth. [1]

.....
.....

- (c) Outline, using your answer to (b)(ii) and a labelled diagram, how the distance of Barnard's star from Earth is measured. [3]

.....
.....
.....
.....
.....
.....
.....

(This question continues on the following page)



(Question E1 continued)

- (d) The apparent brightness of Barnard's star is $3.6 \times 10^{-12} \text{ W m}^{-2}$ and its surface temperature is 3800 K.

Given that $1 \text{ pc} = 3.1 \times 10^{16} \text{ m}$, show for Barnard's star

- (i) that its luminosity is of the order of 10^{23} W . [3]

.....

.....

.....

.....

.....

.....

.....

- (ii) that its surface area is of the order of 10^{16} m^2 . [3]

.....

.....

.....

.....

.....

.....

.....

E2. This question is about the development of the universe.

- (a) Light from distant galaxies, as seen by an observer on Earth, shows a red-shift. Outline why this observation suggests that the universe is expanding. [2]

.....

.....

.....

.....

- (b) The future development of the universe is determined by the relationship between the apparent density of the universe and the critical density.

- (i) Define the term *critical density*. [1]

.....

.....

- (ii) Discuss how the density of the universe determines its future development. Your discussion should include **one** problem associated with determining the density of the universe. [4]

.....

.....

.....

.....

.....

.....

.....

.....

.....



Please **do not** write on this page.

Answers written on this page
will not be marked.



Option F — Communications

F1. This question is about modulation and bandwidth.

- (a) Distinguish between a signal wave and a carrier wave. [2]

Signal wave:

Carrier wave:

(This question continues on the following page)



(Question F1 continued)

- (b) Audio signals can be converted to electrical signals and then transmitted using a process called modulation.

Describe, with reference to your answer to (a), the process of

- (i) amplitude modulation. [2]

.....

.....

.....

.....

.....

- (ii) frequency modulation. [3]

.....

.....

.....

.....

.....

.....

.....

(This question continues on the following page)



(Question F1 continued)

(c) A carrier wave of frequency f_c is amplitude modulated by a signal wave of a single frequency f_s . The bandwidth of the modulated wave is 10kHz. There are 1.8×10^4 complete oscillations of the carrier wave between two adjacent amplitude maxima of the carrier wave.

(i) Explain, with reference to the sideband frequencies of the modulated wave, why the frequency $f_s=5.0\text{kHz}$. [3]

.....
.....
.....
.....
.....
.....
.....

(ii) Show that the frequency $f_c=90\text{MHz}$. [2]

.....
.....
.....
.....



F2. This question is about the digital transmission of information.

(a) State **two** advantages of using digital rather than analogue signals in the transmission of information. [2]

1.
2.

(b) The diagram shows the essential components of a digital data transmitter.

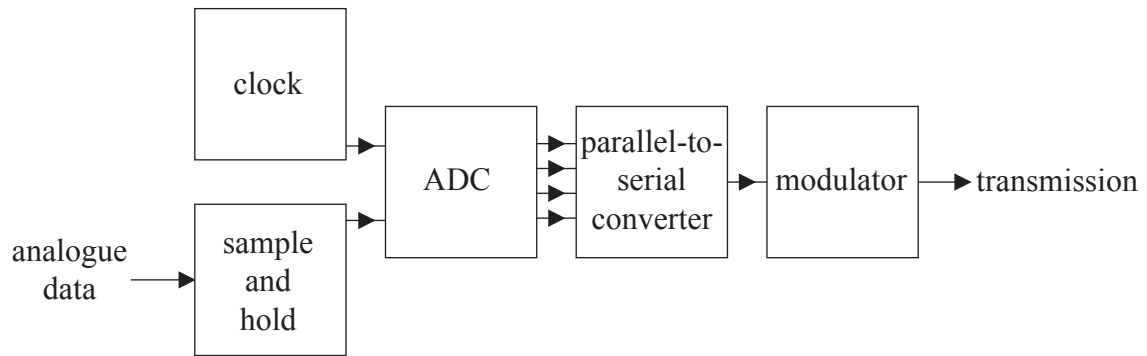

State the function of the

(i) clock. [1]

.....

(ii) ADC. [1]

.....

(This question continues on the following page)



(Question F2 continued)

- (c) The transmitter in (b) is designed to transmit data at a rate of 2.0Mbs^{-1} using an 8-bit binary code. Calculate the frequency at which the sample and hold must operate. [1]

.....

.....

(This question continues on the following page)



(Question F2 continued)

- (d) Digital information that is transmitted along optic fibres is often subject to dispersion due to light taking different paths along the fibre.

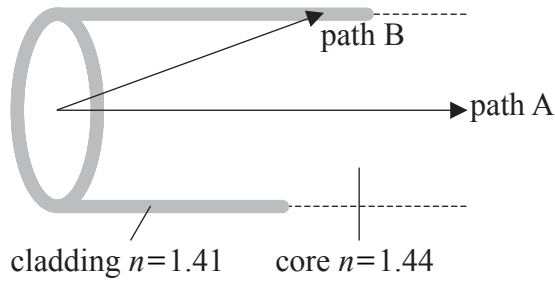

In a particular optic fibre of length 2.00×10^4 m, the refractive index of the cladding is 1.41 and that of the core is 1.44.

Two possible light paths are:

Path A: along the central axis of the fibre.

Path B: the path followed by light that is initially incident on the cladding at an angle just greater than the critical angle.

The speed of light in the core of the fibre is 2.10×10^8 m s⁻¹.

Show that the difference in transmission time between path B and path A is approximately $2.0 \mu\text{s}$.

[3]

.....

.....

.....

.....

.....

.....

.....

Please **do not** write on this page.

Answers written on this page
will not be marked.



3136

Turn over

Option G — Electromagnetic waves

G1. This question is about the electromagnetic spectrum.

- (a) Outline the nature of electromagnetic waves. [2]

.....
.....
.....
.....

- (b) Explain why the ozone layer absorbs ultraviolet (UV) radiation. [2]

.....
.....
.....
.....

G2. This question is about the compound microscope.

- (a) A convex lens used as a magnifying glass has a focal length of f_e . Derive an expression for the angular magnification when the image is at the near point D . [3]

.....
.....
.....
.....
.....
.....
.....

(This question continues on the following page)



(Question G2 continued)

(b) The convex lens in (a) is used as the eyepiece of a compound microscope.

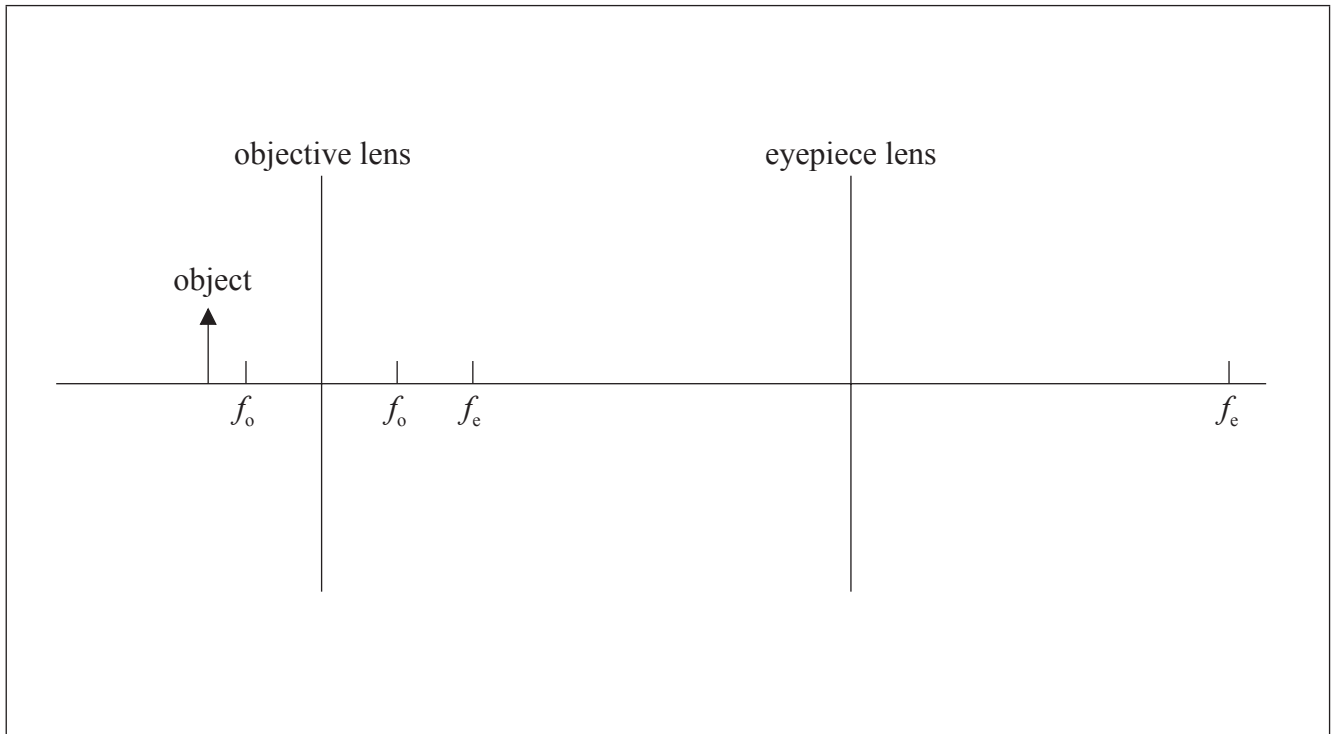

An object is placed 1.5 cm from the objective lens. The focal length f_o of the objective lens is 1.0 cm.

- (i) Draw rays on the diagram to show the formation of the intermediate image. [2]
- (ii) Calculate the distance of the intermediate image from the objective lens. [2]

.....

.....

.....

.....

(This question continues on the following page)



(Question G2 continued)

- (c) Lenses used in the compound microscope are subject to spherical aberration and chromatic aberration.

Explain what is meant by

- (i) spherical aberration.

[2]

.....
.....
.....
.....

- (ii) chromatic aberration.

[2]

.....
.....
.....
.....



G3. This question is about two-source interference.

Coherent light is incident at right angles to a double slit. An interference pattern is observed on a distant screen.

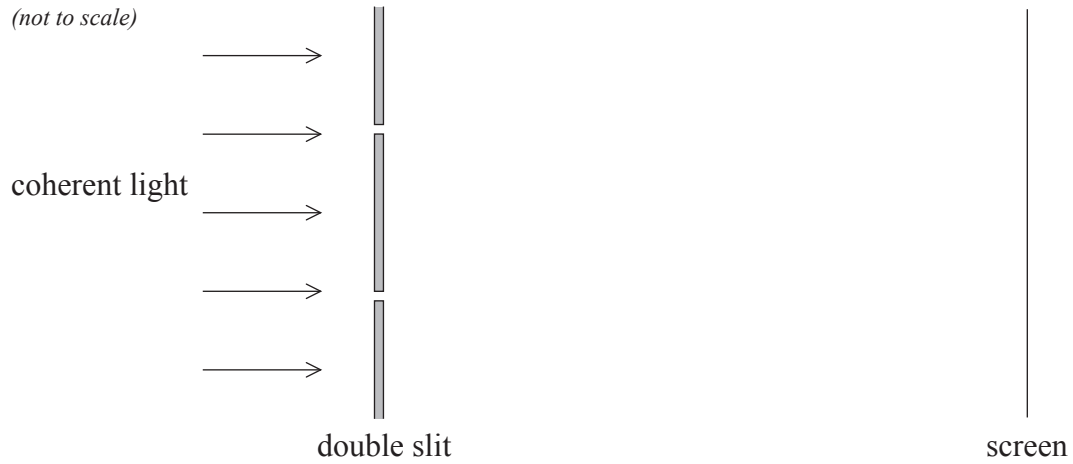

- (a) The width of both slits is now increased without altering their separation. State and explain the effect, if any, of this increase on the intensity of the bright fringes and the appearance of the dark fringes. [3]

.....

.....

.....

.....

- (b) The number of slits is now increased. State and explain the effect, if any, this has on the appearance of the bright fringes. [2]

.....

.....

.....

.....

.....

.....



Please **do not** write on this page.

Answers written on this page
will not be marked.



3636